

**ORIGINAL ARTICLE****ERGONOMICS RISK ASSESSMENT OF WORKER'S TASKS AT CPJ FARM: AN ADVANCED ASSESSMENT USING REBA METHODOLOGY**Najwa Nazihah Ishak<sup>1</sup>, Salwa Mahmood<sup>1</sup>, Mohd Zakwan Zulkifli<sup>2</sup><sup>1</sup>Department of Mechanical Engineering Technology, Faculty of Engineering Technology, Universiti Tun Hussein Onn Malaysia, Pagoh Campus, KM 1 Jalan Panchor, 84600 Pagoh, Johor<sup>2</sup>Chareon Pokphand Jaya (CPJ) Farm Kulai, Lot 188, Jalan Sg. Sayong, 81800 Kulai, Johor, Malaysia

(\*Corresponding author's e-mail: msalwa@uthm.edu.my)

**ABSTRACT**

Agriculture sector is regarded as one of the essential industries worldwide and one of the unsafe sectors in developing and the developed worlds. Initial Ergonomics Risk Assessment (ERA) and Rapid Entire Body Assessment (REBA) tools have been used to analyze the worker's posture in the maintenance department at Chareon Pokphand Jaya (CPJ) Farm Kulai. However, this kind of job might contribute musculoskeletal disorder (MSDs) related injuries, as it mostly involves tough tasks. The purpose of this project is to evaluate the ergonomics risk factors of workers' and intended to analyze the condition of the selected task in the maintenance department at CPJ Farm Kulai. This assessment focused on cutting and welding tasks workers' posture. This project was conducted using the ERA checklist and REBA worksheet. Kinovea software was also used to help observe and assess the worker's working posture. The initial ERA scores for the cutting and welding tasks are more than the minimum requirement for advanced assessment which indicates the need for further investigation. An advanced ERA needs to be performed to reduce risk factors. The results of REBA show that score obtained were 5 for both the cutting and welding tasks. Based on these scores, the worker was at medium risk for MSDs and cumulative trauma disorder (CTDs). Finally, a new ergonomic workstation design for a worker is proposed to minimize and eliminate the risk of work-related to entire body disorder exposure.

**Keywords:** Ergonomics, Musculoskeletal Disorders, Ergonomic Risk Factors, Ergonomics Risk Assessment, Rapid Entire Body Assessment

**INTRODUCTION**

Agricultural work is one of the activities affecting workers with potential risks (Sadeghi et al., 2014). In both the developing and the developed countries, agriculture is considered one of the dangerous industries. Therefore, it attracts more attention to the implementation of realistic actions in agricultural settings to help mitigate work-related injuries and diseases (Sadeghi et al., 2014). It is attracting increased attention concerning practical actions in agricultural settings to help reduce work-related accidents and illness. In agricultural-based activities, most farmers are exposed to several kinds of occupational hazards, such as ergonomic problems, awkward postures, handling of materials, and exposure to chemical and even biological agents. Also, workers have a high prevalence of musculoskeletal complaints, including back injuries, shoulder pain, tendonitis, reduced muscle strength, carpal tunnel syndrome, white finger and knee joint diseases.

Ergonomics is defined as evaluating workplace, equipment, process, method, product, environment, and system design to suit the work to the person. It recognizes human weaknesses and capabilities in physical, behavioral, and psychological capabilities and optimizes work processes' performance and competitiveness while maintaining workers' safety and health (Fernandez & Goodman, 2000).

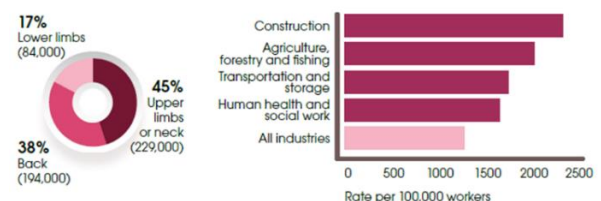

**Figure 1: The affected body part and industries with higher rates of MSDs**

Source: (Safety & Executive, 2017)

CTD is a general term for disorders defined by discomfort, weakness, injury, or chronic pain in limbs, muscles, and tendons. Other terminologies used to describe these conditions include repetitive stress injuries (RTIs), repetitive strain injuries (RSIs), musculoskeletal disorders (MSDs), and occupational overuse syndrome (Fernandez & Goodman, 2000). Musculoskeletal disorder is universal and summarized in all industries around the world. According to the Health and Safety Executive of the United Kingdom, Figure 1 shows that back and upper limb injuries (shoulder, elbow, wrist, and hand) recorded the highest injury ratio. The primary industries are construction, agriculture, and human health and social work.

This project aims to evaluate the ergonomic risk factors among the workers in the maintenance department by conducting initial and advanced level ergonomic risk assessment including ERA and REBA.

The ERA conducted were based on ERA guidelines 2017 released by DOSH (DOSH, 2017). An ERA is a way of maintaining workers' health and safety, enhancing their effectiveness and productivity. There have been many activities among workers that might contribute to workers' injury and illness, especially involving tough tasks such as cutting and welding. The workers might be exposed to WMSDs and Repetitive Strain Injury (RSI). This project is expected to improve the proper working posture based on initial and advanced ergonomics risk assessment, which uses REBA methodology. In addition, this project also proposed an initial design of ergonomics table for improving worker's posture during working. The physical risk factors include posture, speed, load lifting, vibration, physical stress, and length. ERA method evaluated five regions of the central body; shoulders, wrists, back, neck, and legs. Therefore, any risk assessment must apply directly to people who are undertaking or affected by the task being considered.

## LITERATURE REVIEW

Human factors ergonomics is a research discipline concerned with understanding the relationship between people and other elements of a system and profession that applies theory, concepts, information, and methods to improve human well-being and system efficiency (International Ergonomics Association, 2015).

WMSDs are injuries or disorder of muscles, nerves, tendons, joints, cartilage and spinal cord that are related to exposure to risk factors on the task at the workplace (Wang et al., 2017; Mahmood et al., 2020). Work-related lower back disorders due to manual lifting tasks have long been recognized as one of the primary occupational disabling injuries that affect the quality of life. With the advancement in the field of WMSDs, a range of physical, individual, and psychosocial risk factors are now included in the evaluation. Physical risk factors are based on exposure to physical demands while performing tasks; these include awkward posture, forceful exertion, repetitive movement, contact stress, vibration, and task duration (Aptel et al., 2002). Figure 2 shows an example of MSDs.

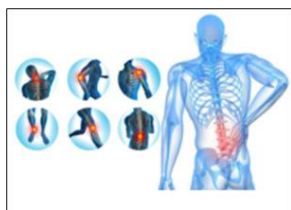

**Figure 2:** Example of MSDs  
**Source:** (Rasya et al., 2019)

Lower-back work-related MSDs affect lumbar spine bones, joints, ligaments, and tendons arising from physical work, manual handling including lifting, twisting, bending vehicle driving

activities, static postures, and prolonged sitting. The lower back job associated MSDs include issues with the spinal disk, muscle and soft tissue injuries (Salvendy & Carayon, 1997).

Working on the knees which cause contact stress is also a frequent cause of musculoskeletal injuries. This issue could become more severe if the kneeling posture is maintained for extended periods (Monk et al., 2018). Bending forward at the waist and maintaining the bending over position causes a significant strain on the lower back, compressing the spine. If it happened for a long time, it could damage the shock absorbing pads and disks located between the vertebrae (Sanmugum et al., 2020).

### *Ergonomic Risk Factors*

Ergonomic risk factors are components of a job or work that put the worker under biomechanical stress. Synergistic aspects of MSD threats are ergonomic risk factors. The Occupational Safety and Health Administration (OSHA) explains the significant body of evidence supporting the finding that exposure to ergonomic risk factors in the workplace can cause or lead to the risk of developing an MSD (Aptel et al., 2002).

During their job farmers undergo vibration, forceful exertions, and awkward postures that may lead to lower back disorders. Lower back conditions affect farmers' ability to work and prevention steps and solutions are required for the farmers to adopt to minimize lower back pain. National Institute for Safety and Health (NIOSH) and the National Academy of Science have reviewed existing scientific evidence that includes thousands of epidemiological studies. It indicates that an MSD is most likely to affect or lead to ergonomic risk factors (I think this statement is wrong - Ergonomics risk factors lead to MSD and not the other way around - please verify). Seven physical risk factors in the ERA assessment including repetition motion, awkward posture, vibration, forceful exertions, static posture, contact stress, and environmental risk factor.

The primary causes of injury to workers conducting hot work in the metal steel-related industry are prolonged static postures associated with neck flexion, operating on knees or in positions that produce awkward postures of the spine for extended periods, and hand grips. Additional risk factors include the constant bending, stooping, squatting, and crouching of hot work like welding, grinding and other. Working on the knees which causes contact stress, is also a frequent cause of musculoskeletal injuries. This issue could become more severe if the kneeling posture maintained for extended periods (Sanmugum et al., 2020).

### *Rapid Entire Body Assessment*

REBA has been specifically developed and designed to examine unpredictable working positions in the healthcare and other services sectors (Hignett & McAtamney, 2000). The assessment of the risk factors for exposure is based on a body position diagram, and

three scoring tables. Posture and forceful exertion risk factors are covered in this procedure. The REBA development involved three stages; the documentation of the working posture, the development of the scoring system, and the development of the scale of action steps, which established the level of risk and further actions to be taken. With muscle action, the external loads applied to the body and the form of grip, the REBA technique is applied to classify the entire body's postural disorders (Cremasco et al., 2019). Figure 3 shows the REBA assessment worksheet.

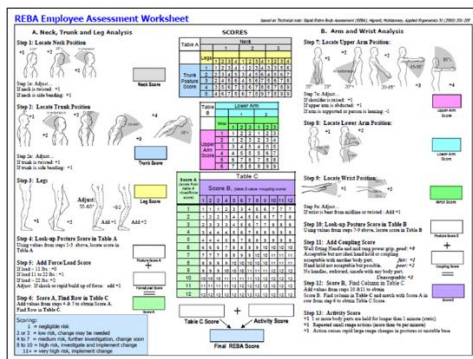

Figure 3: REBA assessment worksheet (Hignett & McAtamney, 2000)

**METHODOLOGY**

An observational method is often used to analyze the ergonomics of the workplace's working posture to determine the MSD and CTD risk factors. For this study, the initial ERA and REBA were chosen to analyze the worker's working posture. The initial ERA and REBA analyses were conducted using worksheets. The number of samples taken is one. The direct observational method is selected for obtaining the best posture of a worker.

An ergonomic risk assessment involves a process from planning, assessing to controlling (DOSH, 2017). This study deals with planning and assessing only. The method used in this assessment follows Guidelines on Ergonomics Risk Assessment at workplace 2017 by the DOSH. Figure 4 shows the methodology flowchart for this project.

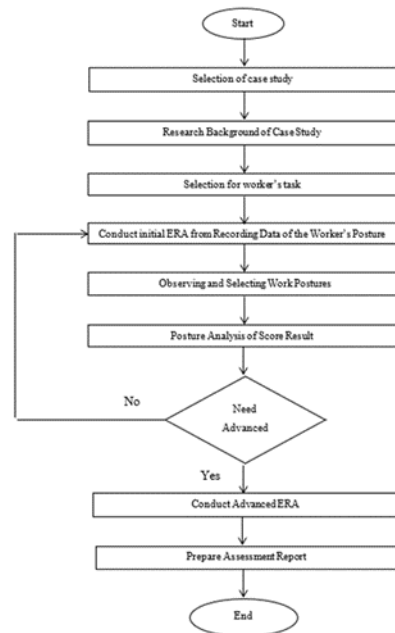

Figure 4: Flow chart of research methodology

*Initial Ergonomic Risk Assessment Methodology*

DOSH introduced the guideline on ergonomic risk assessment at the workplace and provided an ERA worksheet. Initial ERA is the latest checklist drafted under the guidelines of workplace Ergonomic Risk Assessment by the DOSH. Initial ERA based on the types of ergonomic risk factors identified are awkward posture, static sustained work posture, forceful exertion, repetitive motion, hands-arm - whole-body vibration, and finally an environmental factor (Kong et al., 2015).

*Rapid Entire Body Assessment Methodology*

The REBA is an ergonomic body posture assessment method that evaluates the whole body to determine any risk factors concerning the work posture. The REBA analysis worksheet evaluates the work posture, especially body posture, movement, force exerted, and work repetition (Hignett & McAtamney, 2000). The assessment worksheet is divided into two sections: section A includes the neck, trunk, and legs, and section B includes the arms and wrists. The REBA worksheet was used to analyze the working posture risk factors with regard to movement, exertion force, repetitive work, and work posture. The steps used to analyze the working posture using the REBA worksheet are shown in Figure 3.

Three tables determine the REBA score: Table A, Table B, and Table C as shown in Figure3. The score collected in group A will be in Table A and group B in Table B. The muscle use score and force score are added for both scores A and B. The value of scores A and B that have been calculated will be used to find the score in Table C. Figure 5 shows REBA scoring step.

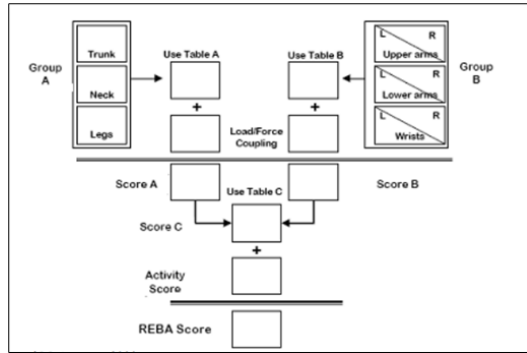

Figure 5: REBA scoring step

The REBA data analysis consists of making decisions while determining the work posture problem risks. Table 5 shows the REBA scoring decisions. A score of one represents a negligible risk. Scores of 2 to 3 and 4 to 7 show low and medium risks, respectively, which require further investigation and possible changes. A score of 8 to 10 represents a high risk, with an investigation and the implementation of a solution required. Finally, a score of 11 or more indicates very high risk, with the implementation of a solution or recommendation being compulsory. Table 1 shows the REBA final score decision.

Table 1: REBA final score decision

Score	Risk of Work Posture Problem
1	Negligible risk
2 - 3	Low risk, changes may be needed
4 - 7	Medium risk, need further investigation and change soon
8 - 10	High risk, need further investigation and implementation soon
11+	Very high risk, implementation soon

DATA ANALYSIS AND RESULT

Initial Ergonomic Risk Assessment Analysis

Initial Ergonomic Assessment was carried out at the maintenance department involving the worker and assess the ergonomic risk assessment using guidelines at workplace released by DOSH Malaysia in year 2017. A worker carried out his daily task, such as cutting, grinding, and welding in the maintenance department. However, this project selects cutting, and welding process with direct observation of the workers, and record the findings based on the checklist. Table 2 shows the score of initial ERA analysis.

Table 2: The score of initial ERA analysis

Risk factors	Minimum requirement for advanced assessment	Result of Initial ERA		Need Advanced ERA (Yes/No)
		Cutting Task	Welding Task	
Awkward Postures	≥ 6	6	6	Yes

Static and sustained work posture	≥1	1	1	Yes
Forceful exertion	1	0	0	No
Repetitive motion	≥1	2	2	Yes
Vibration	≥1	2	2	Yes
Lighting	1	0	0	No
Temperature	1	0	0	No
Ventilation	1	0	0	No
Noise	2	0	0	No

The table of results obtained during the initial ergonomic assessment, which showed the assessment details and the list of ergonomic risk factors identified through the assessment. Based on the analysis, the final ERA score for the cutting and welding working posture more than the minimum requirement for advanced ERA. Both processes fell into the medium-risk category for work posture problems, such as MSDs and CTDs. Those risk factors with a score more than the minimum requirement will proceed for advanced ergonomic risk assessment to further evaluate the identified ergonomic risk factor.

Cutting Task REBA Analysis

Section A consists of an analysis of the positions of the neck, trunk, and leg. Figure 6 shows the REBA analysis based on the angles obtained from the body postures of the neck, trunk, and leg. Table 3 shows the REBA worksheet analysis based on the data provided in Figure 6.

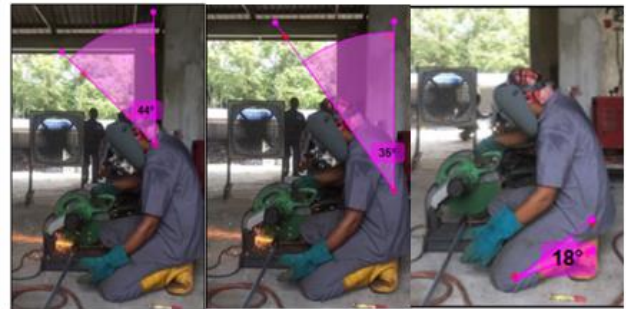

Figure 6: Neck, trunk and leg analysis for REBA

Table 3: REBA assessment score for the neck, trunk and leg analysis

Score	Analysis	Descriptions
+2	Neck Position	The flexion angle of the neck is 44°.
+3	Trunk Position	The flexion angle of the trunk is 35°.
+2	Leg Position	The leg's flexion angle is bent for 18° due to work in a squat and kneeling position.
+0	Force / Load Score	The load is lower than 2 kg.



For section B, the REBA worksheet analysis focuses on the body postures of the upper arms, lower arms, and wrists. Figure 7 shows the analysis method with regard to the worker's body posture including the upper arms, lower arms and wrists by determining the angle of each body posture. Table 4 shows the REBA worksheet analysis based on the data obtained in Figure 7.

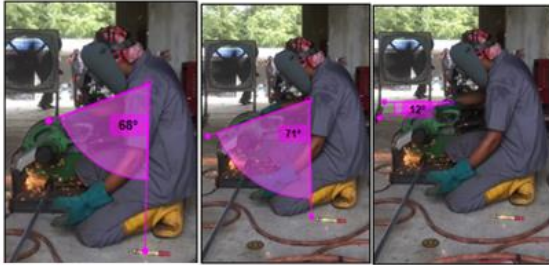

Figure 7: Upper arm, lower arm and wrist analysis for REBA

Table 4: REBA assessment score for the upper arm, lower arm, and wrist position analysis

Score	Analysis	Description
+3	Upper Arm Position	The flexion angle of upper Arm is 68°
+1	Lower Arm Position	The flexion angle of lower upper Arm is 71°
+1	Wrist Position	The flexion angle of wrist is 12°
+0	Coupling Score	Well-fitting handle and mid-range power grip
+1	Activity Score	1 or more body parts are held for longer than 1 minute (static)

**Welding Task REBA Analysis**

Section A consists of an analysis of the positions of the neck, trunk, and leg. Figure 8 shows the REBA analysis based on the angles obtained from the body postures of the neck, trunk, and leg. Table 5 shows the REBA worksheet analysis based on the data provided in Figure 8.



Figure 8: Neck, trunk, and leg analysis for REBA

Table 5: REBA assessment score for the neck, trunk and leg analysis

Score	Analysis	Description
+2	Neck Position	The flexion angle of the neck is 65°.
+3	Trunk Position	The flexion angle of the trunk is 40°.
+2	Leg Position	The flexion angle of leg is bent for 23° due to work in a squat and kneeling position.
+0	Force/Load Score	The load is lower than 2 kg.

For section B, the REBA worksheet analysis focuses on the body postures of the upper arms, lower arms, and wrists. Figure 9 shows the analysis method with regard to the worker's body posture including the upper arm, lower arm and wrist by determining the angle of each body posture. Table 6 shows the REBA worksheet analysis based on the data obtained in Figure 9.



Figure 9: Upper arm, lower arm, and wrist analysis for REBA

Table 6: REBA assessment score for the upper arm, lower arm, and wrist position analysis

Score	Analysis	Description
+1	Upper Arm Position	The flexion angle of upper Arm is 13°
+1	Lower Arm Position	The flexion angle of lower upper Arm is 65°
+2	Wrist Position	The flexion angle of wrist is 27°
+0	Coupling Score	Well-fitting handle and mid-range power grip
+1	Activity Score	1 or more body parts are held for longer than 1 minute (static)

**REBA Analysis Result**

Table 7 shows the REBA analysis for both tasks cutting and welding process. In the REBA analysis, the work posture was divided into two different sections: section A for the arm and wrist analysis and section B for the neck, trunk and leg analysis. Based on the analysis, the final REBA score for the cutting and welding working posture was 5. Both processes fell into the medium-risk category for

work posture problems, such as MSDs and CTDs. Further investigation and advanced ERA are required to determine the actual work posture problems.

Compared to previous research, REBA assessment of the welding task found that a worker with score 8 was categorized as high risk. During the welding process workers do not have a seat that supports the weight, so the workers have to squat and the leg of the workers bend too long (Ariyanti et al., 2019).

**Table 7: REBA assessment analysis**

REBA Analysis	Scoring	
	Cutting Task	Welding Task
<b>A. Neck, truck and leg analysis</b>		
Locate neck position	2	2
Locate trunk position	3	3
Locate leg position	2	3
Posture score A	5	5
Force/load score	0	0
Score A	5	5
<b>B. Arm and wrist analysis</b>		
Locate upper arm position	3	1
Locate lower arm position	1	1
Locate wrist position	1	2
Posture score B	3	2
Coupling score	0	0
Score B	3	2
Table C score	4	4
Activity score	1	1
Final Score	5	5

The graph in Figure 10 shows the score analysis for each part of the REBA assessment worksheet. The neck, trunk, lower arm, force or load and activity scores were the same for both the task of cutting and welding processes. However, the differences between the scores of the two processes were in terms of the upper arm position. The upper arm position score for the cutting process was slightly higher than that for the welding process. Therefore, one can conclude that the cutting process affects the upper arm position more than the welding process.

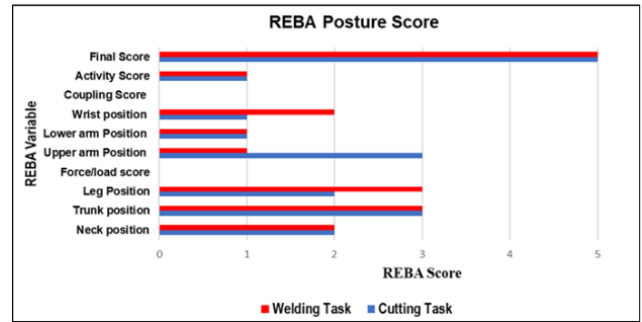

**Figure 10: Analysis of the REBA score**

*Proposed Design of an Ergonomic workstation for a worker*

An ergonomic workstation is needed for a worker based on the initial ERA and REBA score for the cutting and welding process. Figure 11 shows the cutting and welding process ergonomic workstation design. The proposal is to make the workstation design ergonomic, thus eliminating or decreasing the risk of ergonomic injury using appropriate anthropometric measurements standard. The table height should be between 650 mm and 950 mm from the ground, and the table height is designed to be adjusted based on the worker's preference (Mantzari et al., 2019). The table is designed with a footrest to support the legs while standing to reduce fatigue when standing for a long time. Figure 11 shows the proposed ergonomic workstation design.

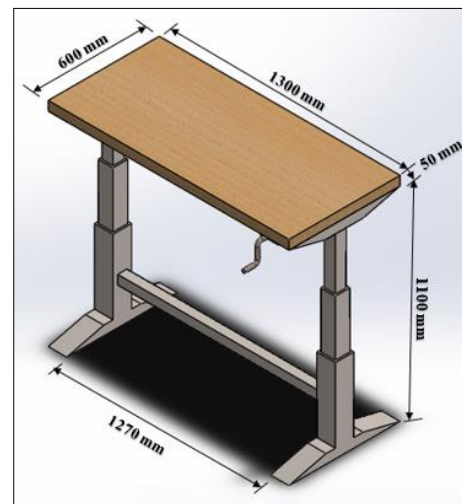

**Figure 11: Proposed Ergonomic workstation design.**

In addition, worker handling heavy work which is cutting and welding task so the suitable height for table of workstation is around 100 mm to 200 mm below the elbow height as shown in Figure 12. The improper design of a standing workstation would make the task more difficult and uncomfortable for the workers, which will affect the quality of work.

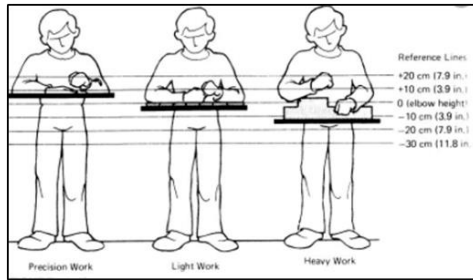

**Figure 12:** The suitable height for workstation (Canadian Centre for Occupational Health and Safety, 2014)

The guideline for standing workstation height by Ergonomic System Associates, workstation heights should be 10 to 20 cm and above the elbow height for precision work. For light work is recommended about 5 - 10 cm higher than the elbow height. For heavy work, the workstation height should be 10 to 20 cm below the elbow height (Ergonomic Systems Associates Incorporated, 2009).

## CONCLUSION

In conclusion, the cutting and welding tasks have been analyzed using initial ERA and REBA method. The worker's work posture was examined by using initial ERA and REBA methods analysis. From the final results, both tasks show that the working postures of the workers possibly lead to injuries such as WMSDs and RSI.

The cutting and welding tasks analysis was conducted using the initial ERA worksheet, and the final score of awkward posture for these tasks is 6, and the static and sustained work posture score is 1. Plus, a total score of repetitive motion and vibration risk factors is 2, which needs further investigation, and an advanced ERA needs to be performed to reduce the risk factors. However, the REBA score was 5 for both the cutting and welding tasks. It considers as a medium risk where further investigation is needed, and changes to be made soon. The improper working posture will lead to injuries like WMSDs and RSI. The result of the initial ERA and REBA analysis shows that both tasks are categorized in medium risk level and need to be investigated. Thus, it can be concluded that the cutting and welding tasks worker is exposed to the risk of the work posture problem.

## Acknowledgements

Authors would like to thank Ministry of Higher Education Malaysia (MoHE), Universiti Tun Hussein Onn Malaysia (UTHM) for the research funding No. K263 and Chareon Pokphand Jaya (CPJ) Farm Kulai for their research support and opportunities.

## REFERENCES

- Rasya A.E., M, A., Elsayed, S. E., & Reem SS. Dawood. (2019). Work related musculoskeletal disorders among Egyptain physical therapists and years of experience. *International Journal of Physical Therapy and Science*, 89-91.
- Aptel, M., Aublet-Cuvelier, A., & Cnockaert, J. C. (2002). Work-related musculoskeletal disorders of the upper limb. In *Joint Bone Spine*. [https://doi.org/10.1016/S1297-319X\(02\)00450-5](https://doi.org/10.1016/S1297-319X(02)00450-5)
- Ariyanti, S., Widodo, L., Zulkarnain, M., & Timotius, K. (2019). Design Workstation of Pipe Welding with Ergonomic Approach. *SINERGI*. <https://doi.org/10.22441/sinergi.2019.2.003>
- Canadian centre for occupational health and safety. (2014). Work-related Musculoskeletal Disorders (WMSDs) - Risk Factors. *Work-Related Musculoskeletal Disorders (WMSDs) - Risk Factors*. <https://www.ccohs.ca/oshanswers/ergonomics/risk.html>
- Cremasco, M. M., Giustetto, A., Caffaro, F., Colantoni, A., Cavallo, E., & Grigolato, S. (2019). Risk assessment for musculoskeletal disorders in forestry: A comparison between RULA and REBA in the manual feeding of a wood-chipper. *International Journal of Environmental Research and Public Health*. <https://doi.org/10.3390/ijerph16050793>
- Department of Occupational Safety and Health, Ministry of Human Resource, M. (2017). Guidelines on Ergonomics Risk Assessment at Workplace. <http://www.dosh.gov.my/index.php/en/competent-person-form/occupational-health/guidelines/ergonomic/2621-01-guidelines-on-ergonomics-risk-assessment-at-workplace-2017/file>
- Ergonomic Systems Associates Incorporated. (2009). Guidelines for the Design of Standing Workstations. *Ergonomic Systems Associates*. <https://ergosystems.ca/>
- Fernandez, J. E., & Goodman, M. (2000). Managing Ergonomics in the Workplace. *Exponent Health Group*, 229-235.
- Hignett, S., & McAtamney, L. (2000). Rapid Entire Body Assessment (REBA). *Applied Ergonomics*. [https://doi.org/10.1016/S0003-6870\(99\)00039-3](https://doi.org/10.1016/S0003-6870(99)00039-3)
- International Ergonomics Association. (2015). *Ergonomics*. *WebPage*. [https://www.ergonomics.org.uk/Public/Resources/What\\_is\\_Ergonomics\\_.aspx](https://www.ergonomics.org.uk/Public/Resources/What_is_Ergonomics_.aspx)
- Kong, Y. K., Lee, S. J., Lee, K. S., Kim, G. R., & Kim, D. M. (2015). Development of an ergonomics checklist for investigation of work-related whole-body disorders in farming. *Journal of Agricultural*

<https://doi.org/10.13031/jash.21.10647>

Mahmood, S., Aziz, S. A. H. S. A., Zulkifli, M. Z., & Marsi, N. (2020). Rula and reba analysis on work postures: A case study at poultry feed manufacturing industry. *Journal of Computational and Theoretical Nanoscience*. <https://doi.org/10.1166/jctn.2020.8716>

Mantzari, E., Galloway, C., Wijndaele, K., Brage, S., Griffin, S. J., Marteau, T. M., Chambers, A. J., Robertson, M. M., Baker, N. A., & The State of Queensland. (2019). Ergonomic guide to computer-based workstations Table of contents. *Applied Ergonomics*, 78(June 2018), 37-53. <https://doi.org/10.1016/j.apergo.2019.01.015>  
<https://doi.org/10.1016/j.pmedr.2018.11.012>

Monk, B. Y. A., Kester, J., Risk, M., & January, C. (2018). Welding ergonomics Worker protection also delivers productivity gains. 1-10.

Sadeghi, H., Karuppiah, K., Bahri, S., & Dalal, K. (2014). Ergonomics in agriculture: An Approach in Prevention of Work-related Musculoskeletal Disorders (WMSDs). *Journal of Agriculture and Environmental Sciences*, 3(2), 33-51.

Safety, H. and, & Executive. (2017). Work-related Musculoskeletal Disorders (WRMSDs) Statistics in Great Britain 2017. Health and Safety Executive. <https://www.hse.gov.uk/statistics/overall/hsh1617.pdf>

Salvendy, G., & Carayon, P. (1997). Data collection and evaluation of outcome measures. In *Handbook of human factors and ergonomics*.

Sanmugum, S., Karuppiah, K., & Sivasankar. (2020). Ergonomic risk assessment on selected hot-work workers at company XXX. *Malaysian Journal of Public Health Medicine*, 20(Specialissue1), 176-185. <https://doi.org/10.37268/MJPHM/VOL.20/NO.SPECIAL1/ART.688>

Wang, J., Cui, Y., He, L., Xu, X., Yuan, Z., Jin, X., & Li, Z. (2017). Work-related musculoskeletal disorders and risk factors among Chinese medical staff of obstetrics and gynecology. *International Journal of Environmental Research and Public Health*. <https://doi.org/10.3390/ijerph14060562>